

BRONZE GLOBE

250 PSI, 1" - 10"
FLANGED END, B.B., MONEL TRIM
GLOBE STOP CHECK

FIGURE NO. NB25221E

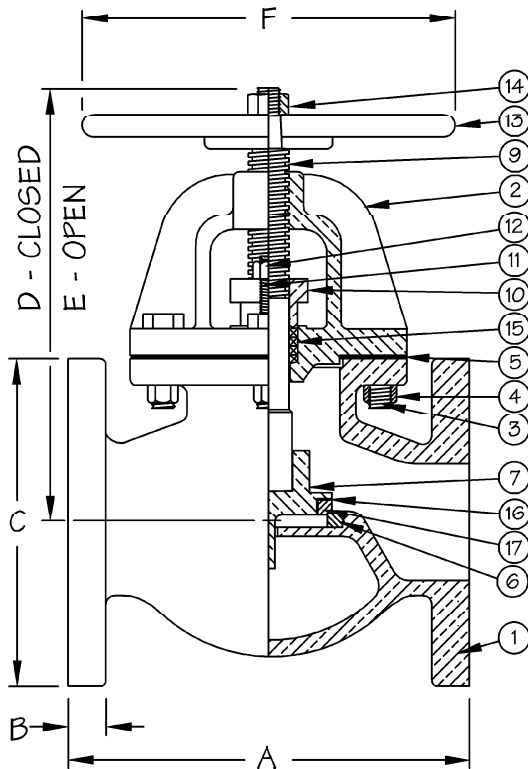

BILL OF MATERIALS			
PART	MATERIAL	SPEC.	
1	BODY	BRONZE	ASTM B61
2	BONNET	BRONZE	ASTM B61
3	BONNET BOLT	NI-CU ALLOY	QQ-N-281, CL. A
4	BONNET NUT	NI-CU ALLOY	QQ-N-281 CL. A or B
5	BONNET GASKET	SYNTHETIC RUBBER	MIL-PRF-1149, CL. 2
6	SEAT RING	NI-CU ALLOY	ASTM A494, GR. M30H
7	DISC*	BRONZE	ASTM B61
9	STEM	NI-CU ALLOY	QQ-N-281, CL. A
10	PACKING GLAND	BRONZE	ASTM B61
11	GLAND STUD	NI-CU ALLOY	QQ-N-281, CL. A
12	GLAND NUT	NI-CU ALLOY	QQ-N-281, CL. A or B
13	HANDWHEEL	ALUMINUM	803-1385620
14	WHEELNUT	SILICON BRONZE	ASTM B98
15	STEM PACKING	SYNTHETIC TEFLON	COMMERCIAL
16	SILVER SOLDER	SILVER SOLDER	MIL-S-15395
17	INSERT	NI-CU ALLOY	QQ-N-288, COMP. A
32	SOLID MONEL DISC	NI-CU ALLOY	ASTM A494, GR. M30C
33	DISC ASSEMBLY	PCS 7, 16 & 17	SEE INDIVIDUAL PIECES

*WHEN FURNISHED AS SOLID MONEL USE PART NO. 32.
CAN BE FURNISHED AS STOP, FIGURE NO. NB25222E (PG.122)

DIMENSIONS

SIZE	1	1-1/2	2	2-1/2	3	4	5	6	8	10
A	6 $\frac{1}{2}$	6 $\frac{3}{4}$	7 $\frac{3}{4}$	8 $\frac{3}{4}$	9 $\frac{3}{4}$	11 $\frac{7}{8}$	14 $\frac{3}{4}$	14 $\frac{3}{4}$	20 $\frac{1}{4}$	25 $\frac{3}{8}$
B	3 $\frac{3}{4}$	13 $\frac{13}{16}$	13 $\frac{13}{16}$	15 $\frac{15}{16}$	15 $\frac{15}{16}$	1	1 $\frac{1}{16}$	1 $\frac{3}{16}$	1 $\frac{5}{16}$	1 $\frac{7}{16}$
C	4 $\frac{1}{4}$	5 $\frac{1}{16}$	5 $\frac{9}{16}$	6 $\frac{1}{8}$	6 $\frac{5}{8}$	7 $\frac{11}{16}$	9 $\frac{1}{16}$	10 $\frac{1}{8}$	12 $\frac{3}{8}$	15
D	6 $\frac{9}{16}$	7 $\frac{3}{4}$	8 $\frac{1}{4}$	9 $\frac{1}{2}$	10 $\frac{1}{16}$	12 $\frac{1}{8}$	15 $\frac{1}{2}$	15 $\frac{1}{2}$	20 $\frac{1}{2}$	24 $\frac{1}{16}$
E	7 $\frac{1}{8}$	8 $\frac{5}{16}$	8 $\frac{3}{4}$	10 $\frac{3}{16}$	10 $\frac{7}{8}$	13 $\frac{1}{8}$	16 $\frac{7}{8}$	17	22 $\frac{1}{2}$	26 $\frac{9}{16}$
F	6	6	6	8	9	9	12	14	14	18
WT	16	18	32	37	55	84	131	154	314	624

